



# Ice Cream Freezer

# SD 310 E



	Energy efficiency class	Item number	23420310E10000	Taric goods code	84185011
	<b>E</b>	EAN code	5704704015685	QTY in 40HQ	97

### Short Description

- #### Key features
- Flat sliding glass lids with lock
  - 4 strong wire baskets
  - Coated white steel inner liner
  - 4 strong castors
  - Suitable for branding

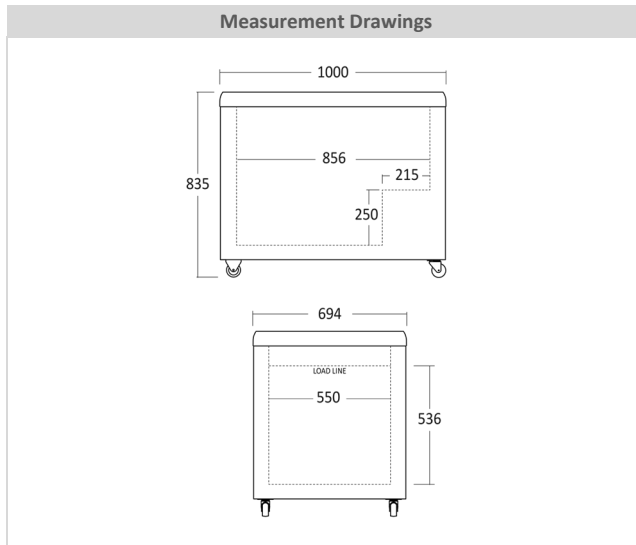

#### Dimensions and weight

Product dimensions, HxWxD, mm	830 x 1000 x 694
Packaging dimensions, HxWxD, mm	890 x 1086 x 770
Total packaging volume m3	0,744
Gross volume, L	284
Net volume, L	223
Gross- / Net volume, L	284 / 223
Internal dimensions, HxWxD, mm	636 x 856 x 550
Gross- / Net weight, kg	68 / 60

#### Performance and consumption

Energy efficiency class	E
Daily Energy Consumption, kWh/24	2,137
Annual energy cons. kWh/a	780
Energy Efficiency Index (EEI)	50,8
Refrigeration / freezing technique	Static
Climate class	7
Type of refrigerant / gas gr.	R290a / 85
Temperature range °C	-18 / -24
Energy efficiency class	E

#### Installation and power

Voltage / hertz, V/hz	230 / 50
Watt / Ampere, W/A	280 / 1.5
Length of Powercord, cm	150

#### Design and comfort

Controller	Mechanical
Control panel	Outside
Digital display	No
Canopy light sign	No
Internal light	1 Horizontal LED
External thermometer	Yes
Handle	Integrated
Number of castors, pcs	4 castors
Lock & Key	Yes

#### Colour and material

Inside Colour	White
Colour and material of door/lid	Sliding glass

#### Interior features

Number of baskets, pcs	4 baskets
Basket Size (HxWxD) (mm)	315 x 210 x 574